

PROJECTNR.:

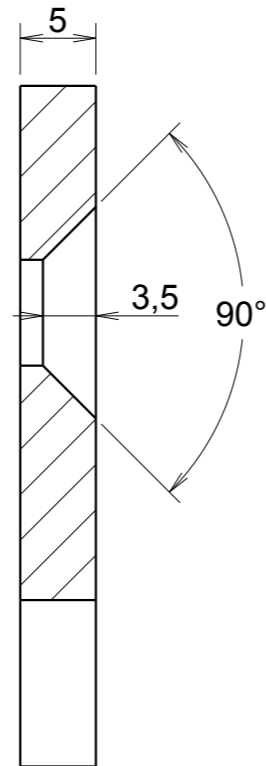

SECTION A-A

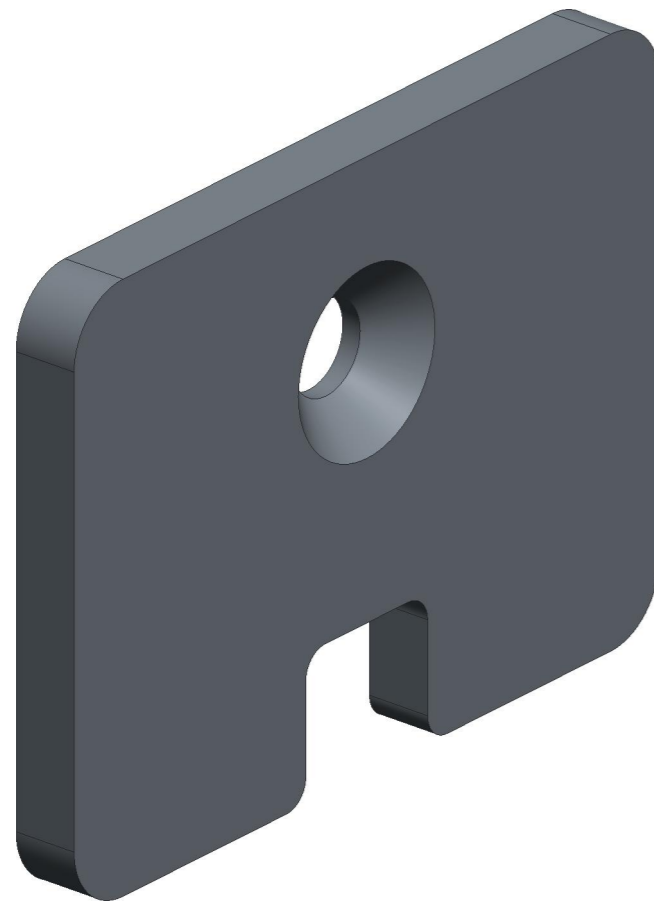
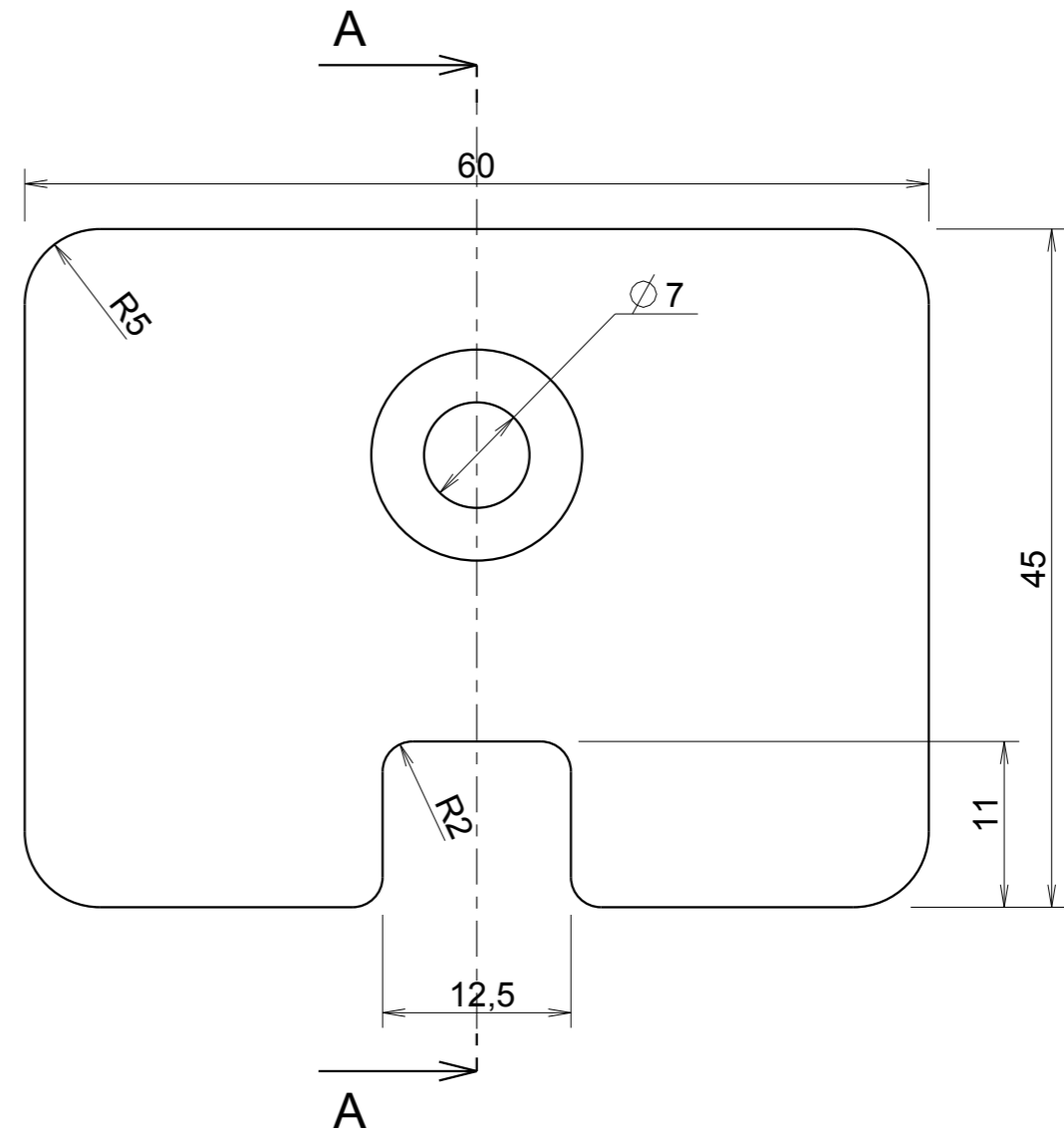

ROTOFINISHING

 VAARTWIJK 7 4571 SV AXEL TEL: +31 (0)115-561740 FAX: +31 (0)115-564661 www.krakertrailers.eu	AMERIKAANSE PROJECTIE	RUIWHEID VOLGENS NEN 3634	MAATTOLERANTIES ALS IN TABEL (TENZIJ ANDERS VERMELD)		VORM- EN PLAATSTOLERANTIES VOLGENS NEN-ISO 1101
	SCHAAL: 2:1 MAATEENHEID: mm OMSCHRIJVING:		MATERIAAL: S420	MASSA: 0,1 KG	BEHANDELING: ELECTRO PLATING
		GETEKEND: M. ACKE	ARTIKELNUMMER: 5020366		<b>A3</b>
		GECONTROLEERD: -	TEKENINGNUMMER: 5020366		REVISIE: A
AANSLAGSTRIP LUCHTVERGR HAAK <small>DEZE TEKENING BLIJFT EIGENDOM VAN KRAKER TRAILERS B.V. EN MAG NIET GEHEEL OF GEDEELTELIIK GEBRUIKT, GEKOPIEERD OF AAN DERDEN TER INZAGE GEGEVEN WORDEN, ZONDER VOORAFGAANDE SCHRIFTELIJKE TOESTEMMING VAN KRAKER TRAILERS B.V.</small>					STATUS: Released

MAAT:	0-6	± 0,2
TOL:	6-30	± 0,5
	30-120	± 0,8
	120-400	± 1,2
	400-1000	± 2,0
	1000-2000	± 3,0
	2000-4000	± 4,0
	4000-8000	± 5,0
	8000-12000	± 6,0
	12000-16000	± 7,0